

WeedSeeker®

Model 650 & PhD600

INSTALLATION and OPERATION MANUAL

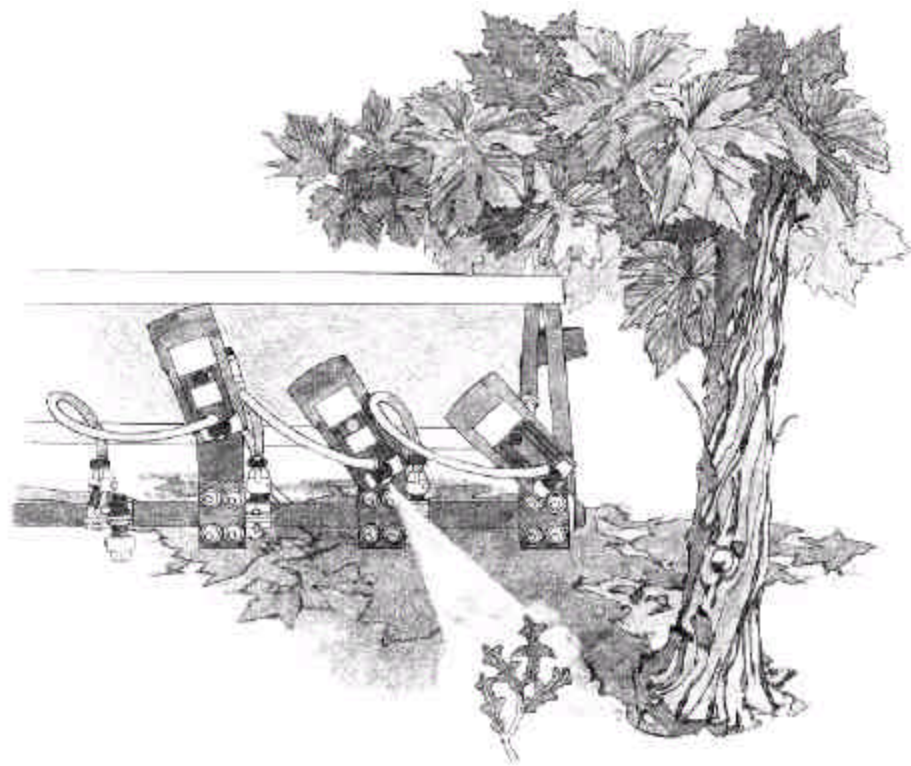

PATCHEN™

1147 North State Street
Ukiah, CA 95482
☎ 707-467-3747 FAX 707-467-3750
e-mail: info@weedseeker.com
www.weedseeker.com

500-1-018
03/00
Rev. F

(THIS PAGE PURPOSELY LEFT BLANK)

Table of Contents

	Page
Introduction	4
Technical Highlights	4
<i>WeedSeeker</i> [®] Sensor	4
Valve Cartridge (VC01)	5
Nozzle	6
Valve Cartridge Driver (VDC05)	7
Controller	8
Boom Setup	10
Electrical Connections	14
Plumbing Hookup	16
Operating Instructions	17
Care and Maintenance	18
Warranty Information	19

Document Part Numbers

Installation and Operation Manual	500-1-018
Troubleshooting Manual	500-1-019
Parts Catalog	500-1-020

Introduction

Congratulations on your purchase of a Patchen *WeedSeeker*[®] Selective Spray System. These units are an innovative step in agricultural spray application and weed control. They are manufactured and tested to provide you with years of dependable service, enhanced weed control, long term cost savings, and reduced environmental impact resulting from reduced application of chemicals. Please read this manual carefully before attempting setup and operation of your *WeedSeeker*[®] system to ensure optimal trouble-free performance.

Technical Highlights

Each *WeedSeeker*[®] Sensor has its own light source, optical detector, and a replaceable Valve Cartridge. The theory behind the operation of the *WeedSeeker*[®] is fairly simple. It is based on the fact that every object has its own individual reflectance signature when exposed to light. For instance, a car tire made of black rubber has a different light reflectance signature than gold jewelry. Dry, sandy soil has a different reflectance signature than moist, loamy soil. The substance in plants that processes sunlight, chlorophyll, has a distinct reflectance signature. The Sensor uses both a visible and an infra-red (LED) light source and a light detector to measure the reflectance of the ground over which it travels. When a live plant comes into the field of view, the detector and electronics within the Sensor recognize the plant's light reflectance signature and direct the valve cartridge to spray a burst of chemical. Spraying is controlled by an extremely fast, highly reliable solenoid valve located inside the Valve Cartridge.

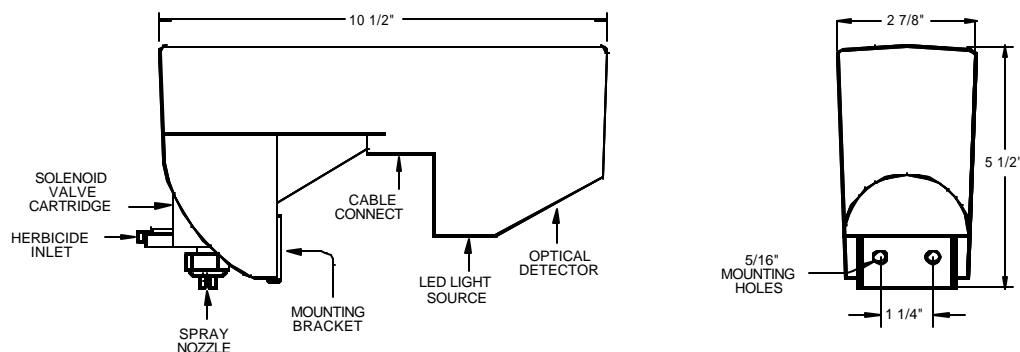

Figure 1: *WeedSeeker*[®] Sensor

WeedSeeker[®] Sensor

The Sensor is an intelligent spray unit. Internally it has a printed circuit board containing sophisticated electronic components and optical devices. The unit is sealed to protect the integrity of these electronic devices. The system also includes a detachable valve cartridge.

Figure 1 labels the functional parts of the Sensor. The front most element is the optical detector. Positioned slightly behind the optical detector is the Light Emitting Diodes, (LED) light source. The LED's emit a modulated light pattern that hits the ground or weed and the reflected light signal is read by the detector. The onboard electronics activates the valve cartridge if a plant is present and opens the nozzle to dispense a burst of chemical. The infrared light emitted by the LED's is not a hazard to look at.

When set at the proper height and pointed straight down, each Sensor will have a Field of View 13" +/- 1/2" wide. When set at an angle, the Field of View will be wider, depending on the angle.

When the **Flush** Switch on the Controller is turned on, the Sensor will energize the Valve Cartridge.

Electrical contact to the Sensor is made through the cable connect socket.

A mounting bracket allows easy assembly to a spray boom. Each Sensor weighs 2.75 pounds.

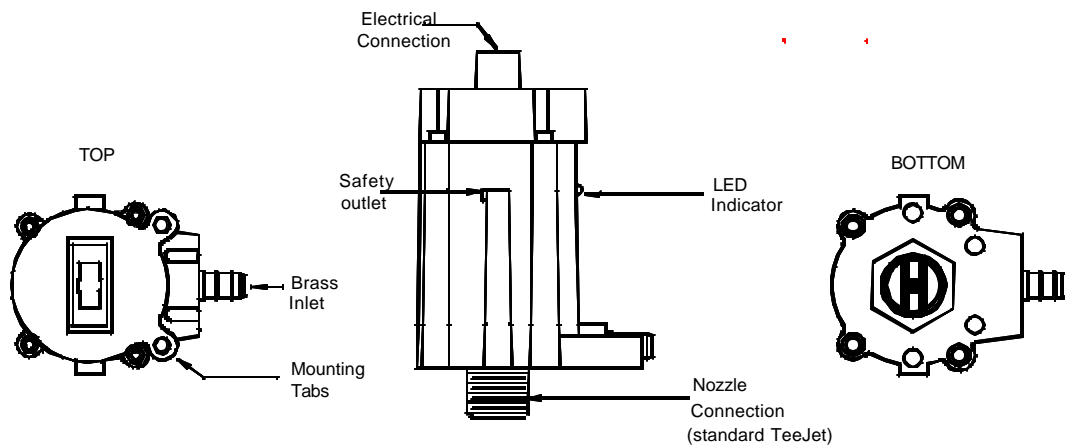

Figure 2: Valve Cartridge (VC01)

Valve Cartridge (VC01)

The Valve Cartridge, Figure 2, comprises a brass inlet (incoming liquid), a spray nozzle, an (LED) indicator light, an electrical connector socket, and two stainless steel screws. The cartridge also includes a safety outlet.

The chemical from the tank enters through the brass insert and is dispensed through the nozzle. The indicator light in the cartridge comes on whenever the nozzle is turned on. A metallic “click” sound can be heard when the cartridge is energized.

The connector socket electrically connects the cartridge to the housing and two stainless steel screws hold the cartridge in place.

Internal to the cartridge is a magnetic filter, solenoid, and a printed circuit board with electronic components. The electronics turn the solenoid on and off as well as the LED indicator light. The internal filter is 160 mesh. The filter and magnet prevent sand, non-dissolved chemical material and magnetic particles in the water from causing problems with the solenoid valve.

It is important that the cartridge be flushed after each day of use with clean water. This can be accomplished by flushing with a clean water source located on the sprayer as shown in Figure 3 or by connecting to a fresh water hose. Failure to do so will allow excessive build up of particulate matter and chemical residue on the valve seat.

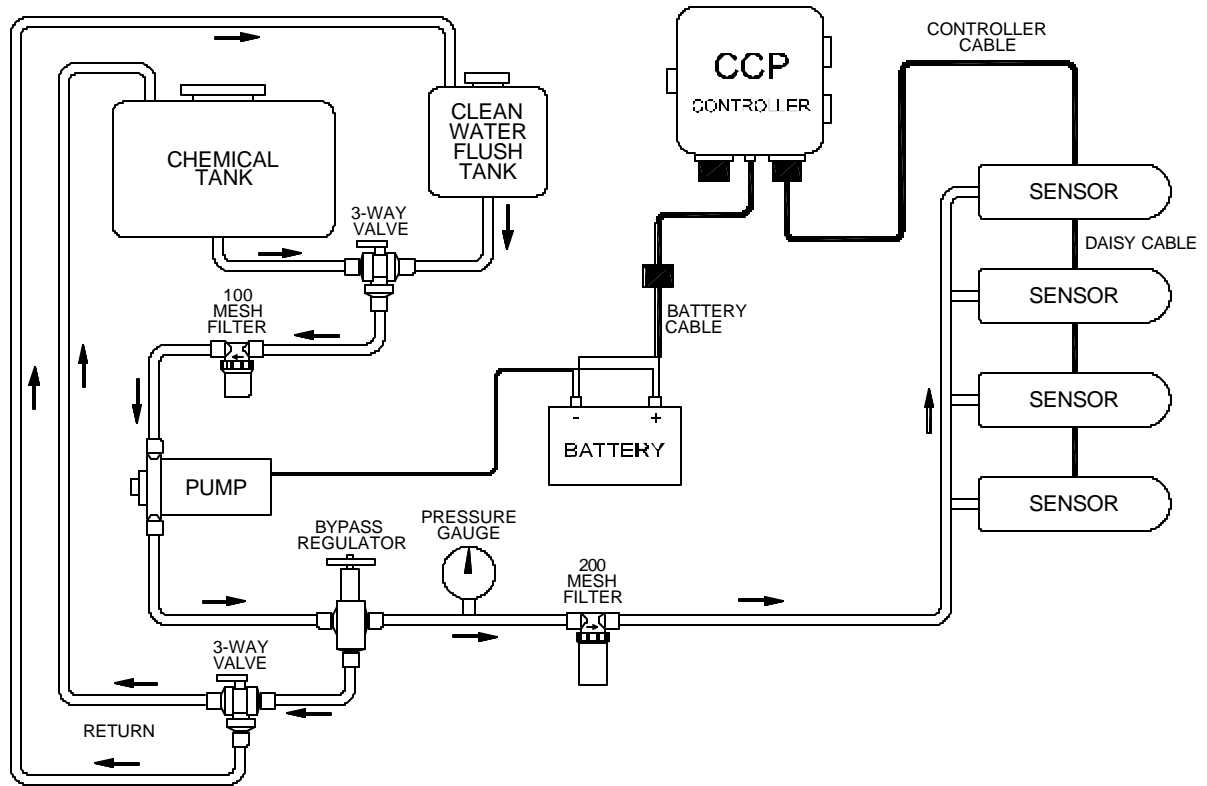

Figure 3: System Plumbing with Clean Water Flush

Nozzle

The Sensor nozzle has been selected to provide an optimum spray pattern. The table below describes the factory-installed nozzle and an alternative nozzle.

Table 1: Nozzle Characteristics

<u>Nozzle</u>	<u>Spray angle</u>	<u>Flow rate (gpm)</u>	<u>Spray pattern width at 23" height</u>
TeeJet™6502	65	0.2	15"
TeeJet™6504	65	0.4	15"

Alternative nozzles may be used to control application rate.

A wider angled nozzle will spray a wider angle than the optical field of view resulting in chemical waste.

Valve Driver Cartridge (VDC05)

The Valve Driver Cartridge is used to drive an external solenoid valve (supplied by the user), in applications that exceed the specifications of the Valve Cartridge (VC01). The VDC05 uses the same cartridge body as the Valve Cartridge, except that the internal circuit board and solenoid valve have been replaced with a valve driver circuit board with a higher amperage rating.

The VDC05 is inserted in the valve cartridge slot of a Sensor and secured with two stainless steel captive screws. When the Sensor detects a plant or weed, the VDC05 will output an electronic signal. This signal is used to open an external valve and activate an external system, such as a spray nozzle or a bank of spray nozzles. The red LED will turn on to indicate that the cartridge is energized.

A Sensor with a VDC05 has the ability to activate:

- a high pressure sprayer when a tree or vine is detected,
- a foliar nutrient or fungicide spray system when a tree or vine is detected,
- a fertilizer ground application system when a tree or vine is detected,
- nozzles capable of spraying wettable powders,
- an application of beneficial insects to plants.

Figure 4 shows the necessary connections for the VDC05. The red wire is connected to the positive side of a 12 volt DC, negative ground battery and the yellow wire is connected to the external solenoid. The external solenoid is then connected to a good ground. The black wire on early versions of the VDC05 should be disconnected and not used. The driver load capacity of the VDC05 is five amps. Therefore, a 10 Amp fuse should be connected between the battery and the VDC05 for over-load protection.

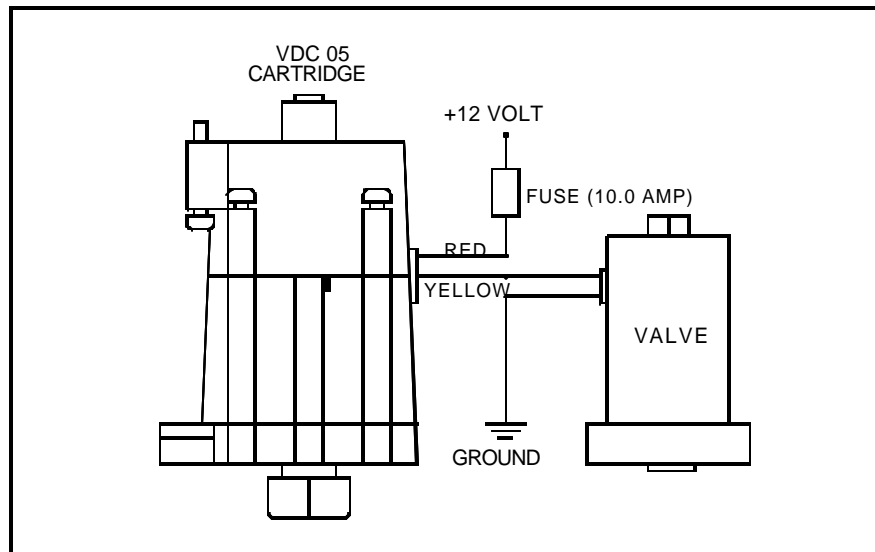

Figure 4: Valve Cartridge Driver Configuration

Controller

One Controller (CCP) or Controller Logic (CL) panel will operate up to sixteen (16) Sensors (with eight units on each of two control cables). Additional CL's are used in larger systems.

A remote Lift Switch on a Row Crop Sprayer, connected to the five foot long cable, will remotely activate the Standby Mode.

The Controller should be placed in a convenient location near the operator, but not so that it interferes with safe vehicle operation.

To properly spray a weed, the time delay before the Valve Cartridge opens and the duration that it stays open must match the vehicle's speed. Since the system does not use a speed-sensing device, the **Speed** Switch selects a range of speeds to control the timing. The system has an operating range of between 3 and 10 miles per hour. When properly set, the spray will turn on slightly before the weed and stay on until slightly after the weed.

Optical calibration of the system occurs when the Soil Base Switch is released. Whatever reflectance signal that is being detected by each Sensor at that instant becomes that Sensor's new Soil Base value. As the sprayer travels through the field, each Sensor compares the current reflectance signal to the Soil Base value it has stored in memory. The Soil Base value represents a certain amount of chlorophyll. An object must have a chlorophyll reflectance signal greater than what is in a unit's memory in order to be sprayed. If the Soil Base was set while a Sensor was over a weed, smaller weeds will not be sprayed, only weeds larger than the initial weed will be sprayed.

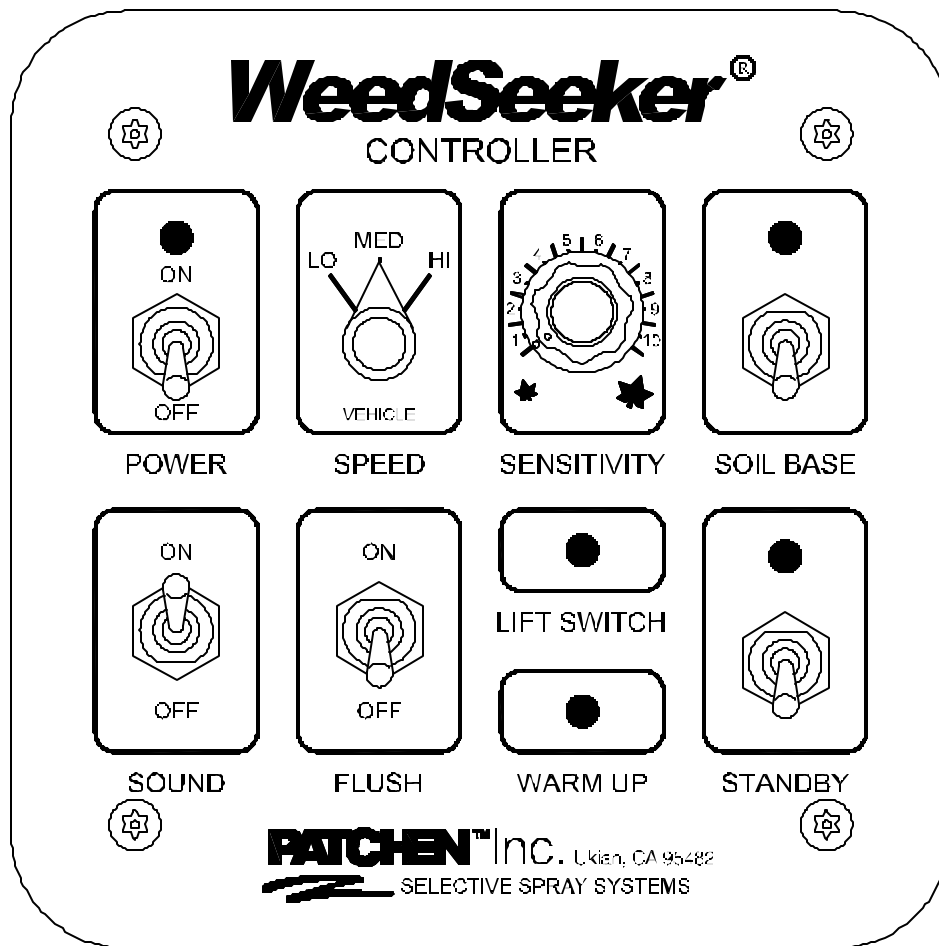

Figure 5: CCP Control Panel

Control Panel functions:

- **POWER** - Switch turns all Sensors connected to that single Controller on and off. Sensor units do not retain settings in memory when turned off.
- **Vehicle SPEED** - Time delay setting to compensate for vehicle speed. **LO** 3 to 5 mph; **MED** 5 to 7 mph; **HI** 7 to 10 mph.
- **SENSITIVITY** - Adjusts the sensitivity of the Sensors for the size of weeds to be sprayed.
- **SOIL BASE** - Resets the background of each Sensor. Select a weed free spot to calibrate the soil base.
- **SOUND** - Switches the Controller sound signal on or off. This is used as a reminder that the system is in the standby mode.
- **FLUSH** - Opens all connected Sensor spray valves.
- **LIFT SWITCH** - Light is on when the standby mode has been activated by a remote switch.
- **WARM UP** - Light is on when the Sensors are first powered up. Goes off when the electronics are up to operating temperature.
- **STANDBY** - Pauses operation of all connected Sensors with the valves closed. The Controller will sound a reminder when it is in standby mode. Soil Base settings are retained in memory while in the standby mode.

Please refer to these definitions and keep them handy for future use.

Boom Setup

The Patchen *WeedSeeker*[®] Selective Spray System is used in Orchards, Vineyards, Row Crop fields, Fallow fields, Irrigation and Industrial applications. Each application requires a different type of mounting platform to hold the Sensors. The type of bar that will be used also depends on where on the vehicle it will be attached.

Selecting a bar to be used with the *WeedSeeker*[®] System is determined by the strip width to be treated and whether the ground is flat or has berms. Figures 6a & 6b show four frequently used orchard and vineyard boom configurations. Figure 6c shows two large boom configurations.

To ensure proper *WeedSeeker*[®] operation, the detector lens should be set 24 inches from the ground in the direction it is pointed. This can be accomplished either by using a bar that steps down, as shown in Figure 6a, or by using a straight bar at a lower level and stepping the Sensors up with the use of mounting plates (not included with standard kits), as shown in Figure 6b. This is the optimal height for the Sensor optics. The Sensor height must be between 18 and 30 inches for the units to "see" properly. The recommended Sensor spacing for vertical alignment (90° to the ground) of more than one unit is 12 inches. This spacing insures proper coverage with one inch sensing overlap between units.

For Row Crops, the *WeedSeeker*[®] Systems are available in 4, 6, 8, 10 and 12 row configurations, for either 36 to 40 inch rows or 26 to 32 inch rows. Custom configurations can be accommodated. The Sensors are placed under plastic hoods to keep non-selective chemicals from drifting onto the crop. The hoods, tank, pump, and hoses are mounted on a tool bar that attaches to a tractor.

For Fallow fields, the Sensors are spaced 12 inches apart on a straight bar so that they are all pointed straight down, as shown in Figure 6c.

Boom for Sensor's with strip coverage with berm.

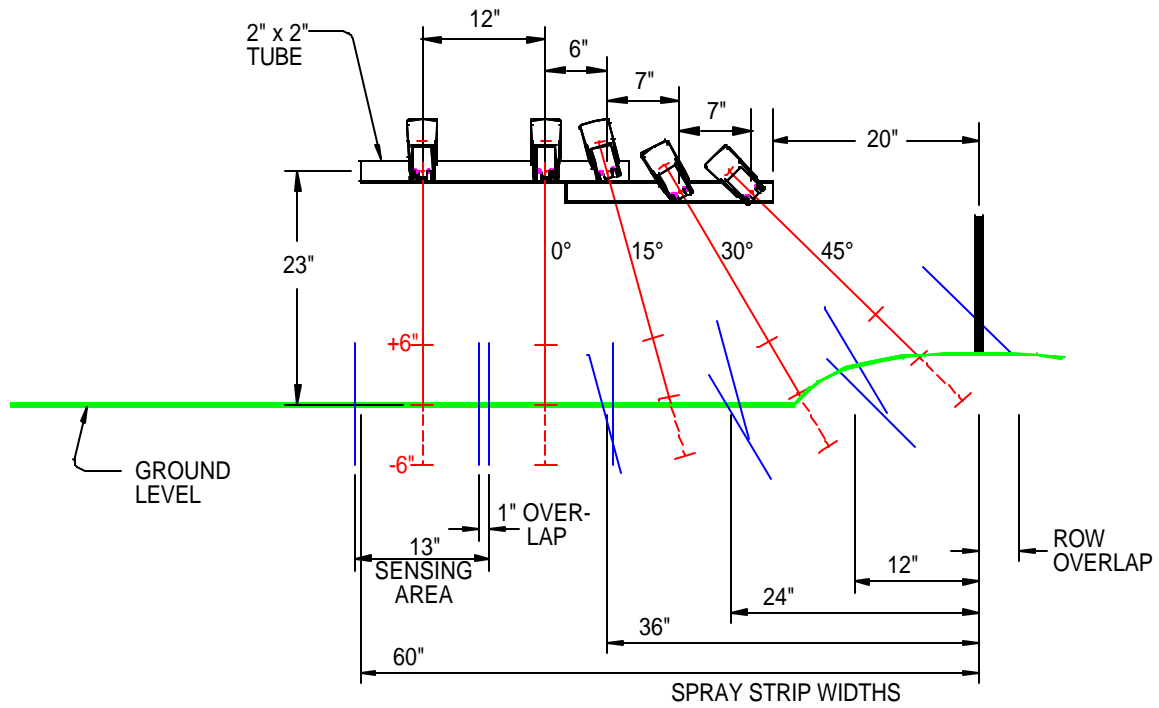

Boom for Sensor's with strip coverage with no (or very low) berm.

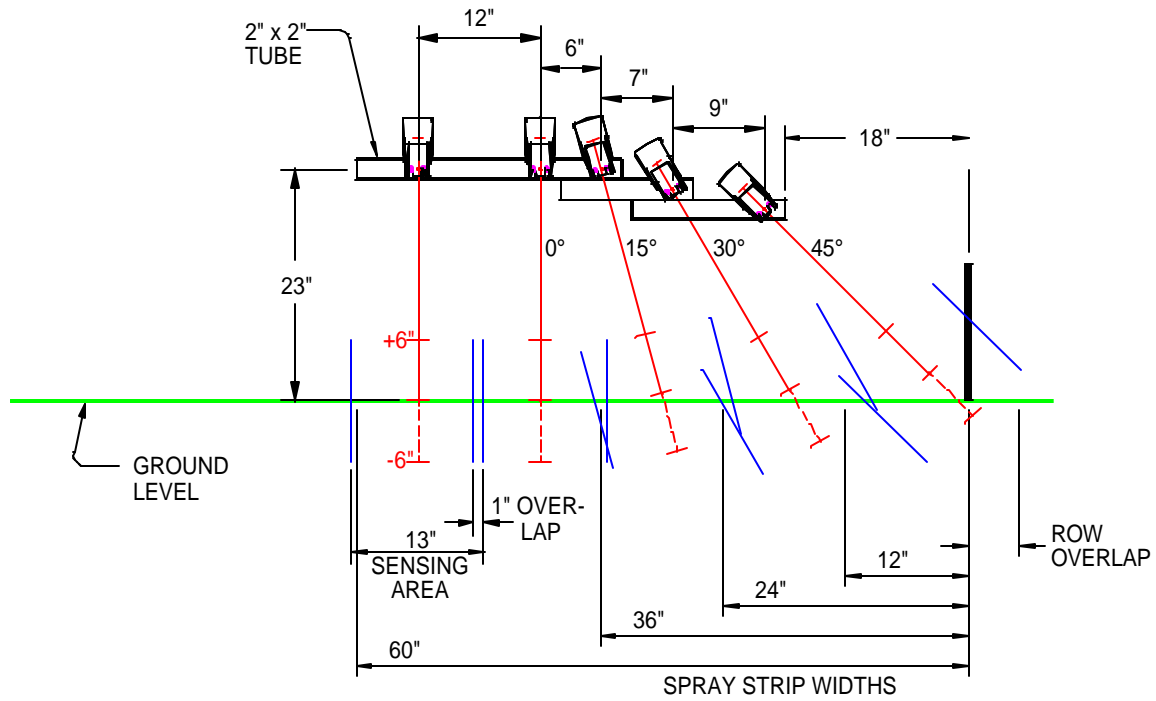
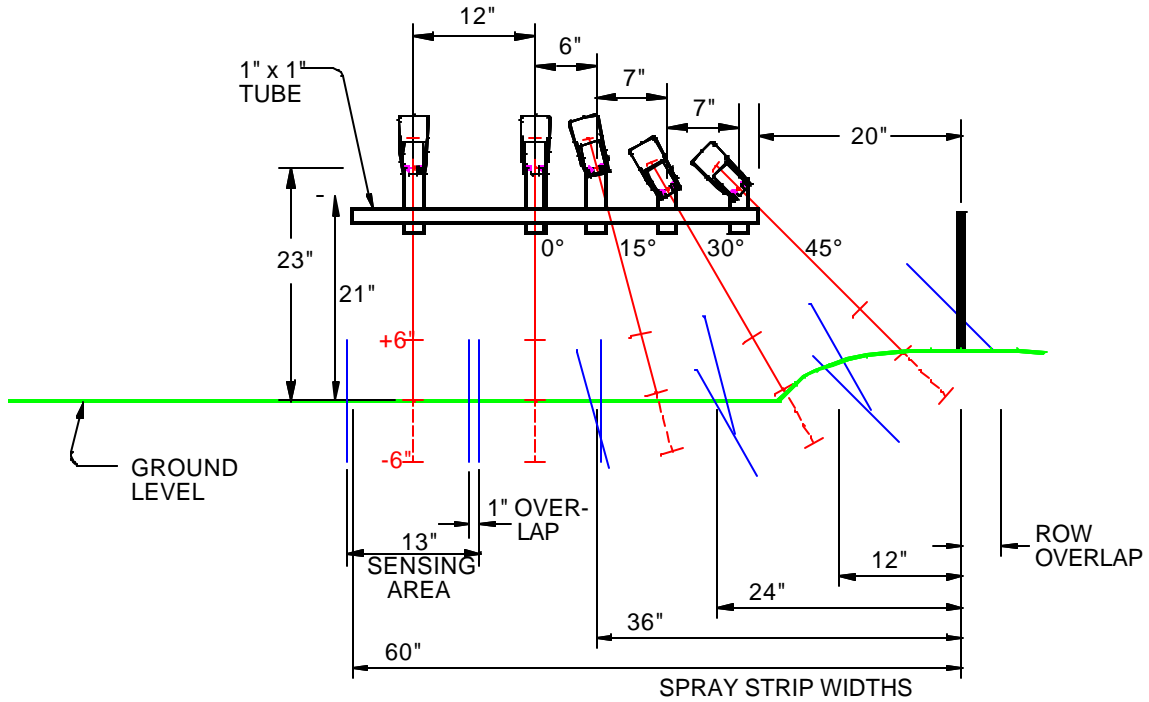

Figure 6a: Boom Configurations, 2" by 2" square tube

Boom for Sensor's with strip coverage with berm.



Boom for Sensor's with strip coverage with no (or very low) berm.

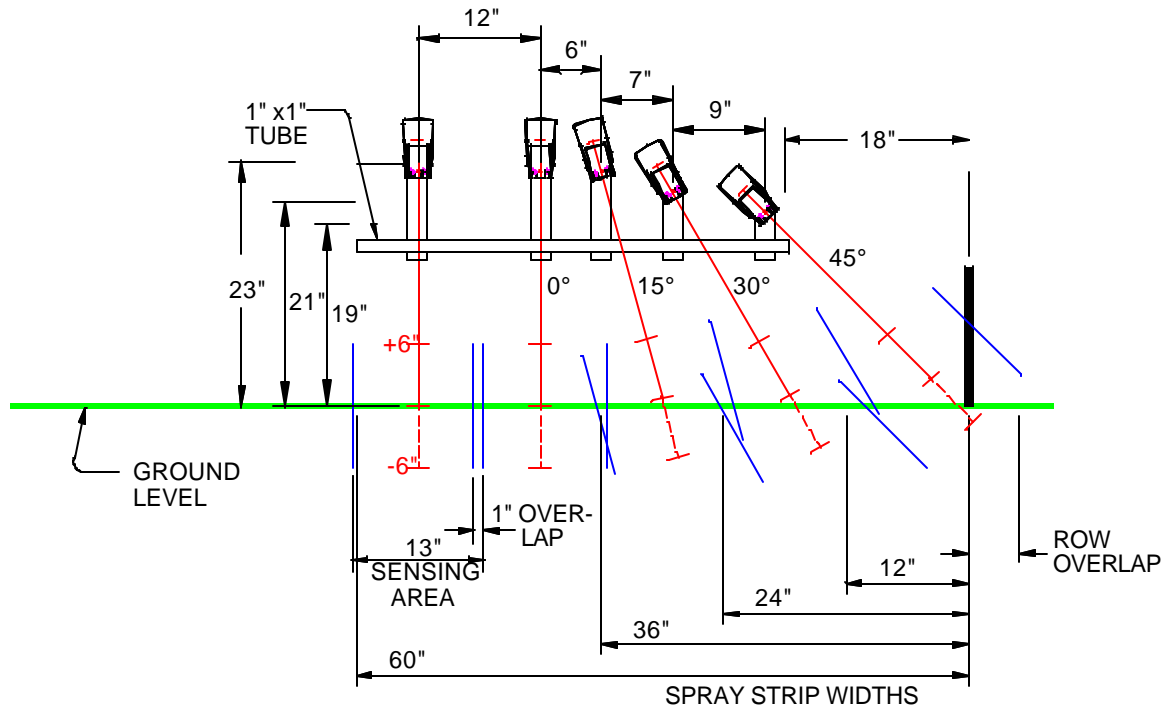
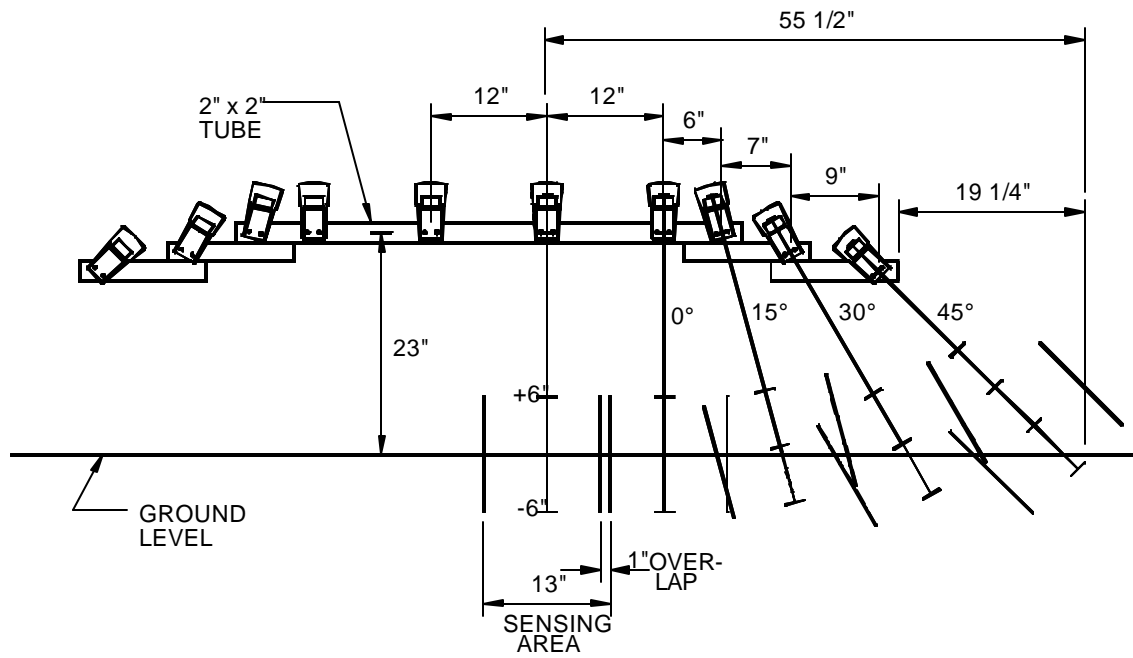

Figure 6b: Boom Configurations, 1" square tube with mounting plates
 Boom for Sensor's for complete coverage, (10 sensors shown as an example)



Boom for Sensor's for complete coverage, (8 sensors shown as an example)

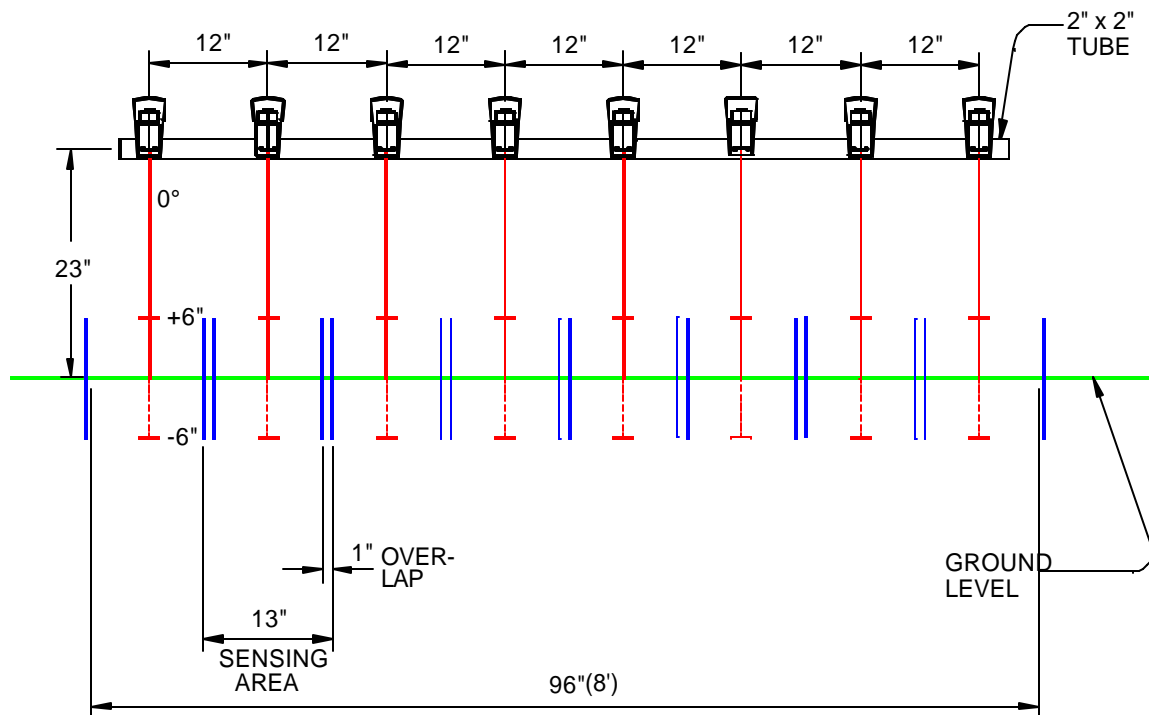

Figure 6c: Boom configurations for large systems

Electrical Connections

Row Crop Systems: Figure 7a illustrates an example of a small, row crop system. The power is located on the tool bar, and then to the Sensors through the Controller Cables, the Hood-to-Hood Connecting Cables and the Daisy Cables. All cables between the Switch Panel and the CL box must be connected before power will be available to the system.

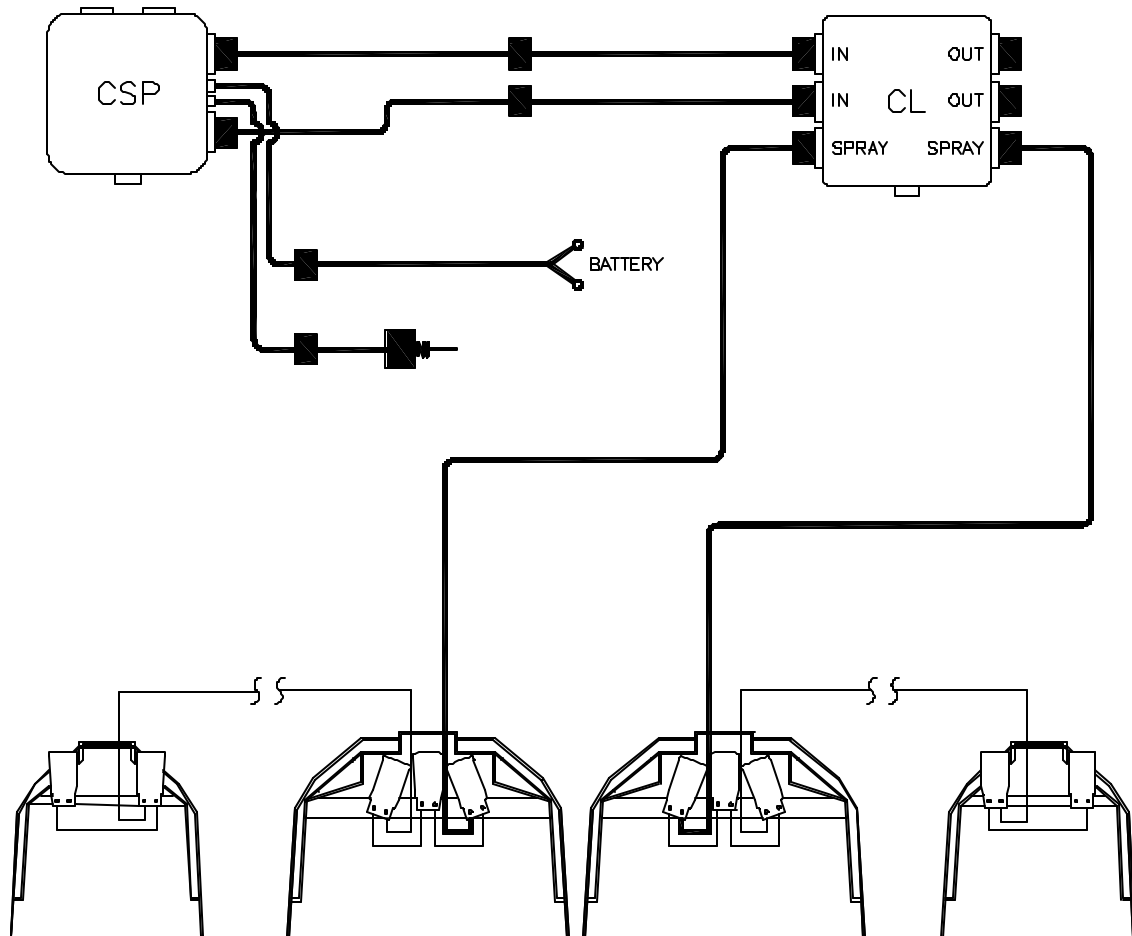

Figure 7a: Electrical Connections for Row Crop Systems

Permanent Crop Systems: Figure 7b illustrates an example of a small, single boom system. The Controller distributes the power directly to the Sensors through the Controller Cables and the Daisy Cables.

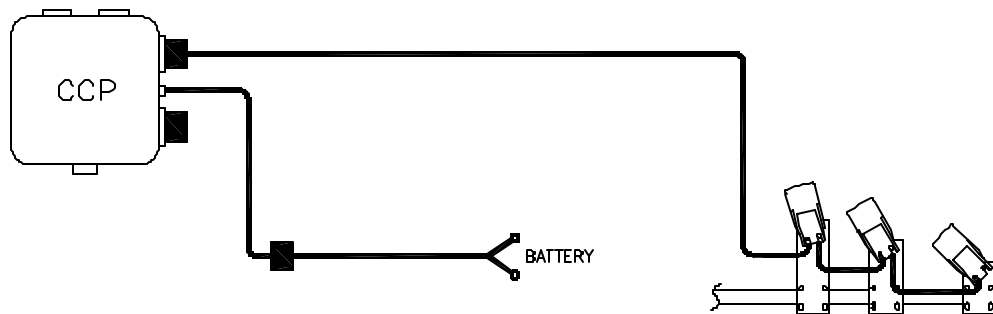

Figure 7b: Electrical Connections for Permanent Crop Systems

Connect the Controller (CCP) or Switch Panel (CSP) directly to a fully charged 12 volt battery, or the Power Cable quick-disconnect may be plugged into a reliable convenience outlet. The red power lead goes to the positive battery terminal, the black one to negative.

The Controller has internal circuits that will prevent the system from turning on if the power source is connected incorrectly, or too high, (19 volts or more), or too low, (10 volts or less), or if the current draw is too great, such as a short in the system.

Note that the 12 pin connectors in the Sensors and on the cables have a key on one side that allows them to be plugged in one way. When they are completely plugged in, the fastener retainer will be against the Sensor base and should be turned to align the Phillips head screws so they can be tightened.

The individual Sensors are interconnected using daisy cables. Do not force the connectors or over-tighten the fastening screws. In each section, cap the last Sensor's unused cable connector with the sensor plugs provided. Place the cables out of harm's way, away from potential catch points and hot or sharp objects. Tie wraps and/or cable clamps are recommended to keep cables free of hazards.

Each *WeedSeeker*[®] Sensor draws 230 mA of current.

Caution: If welding on the tractor or sprayer is necessary, disconnect the power from the battery by removing both the positive and negative leads from the battery terminals. If welding on the spray boom is necessary, disconnect the power and remove the Sensor completely from the spray boom.

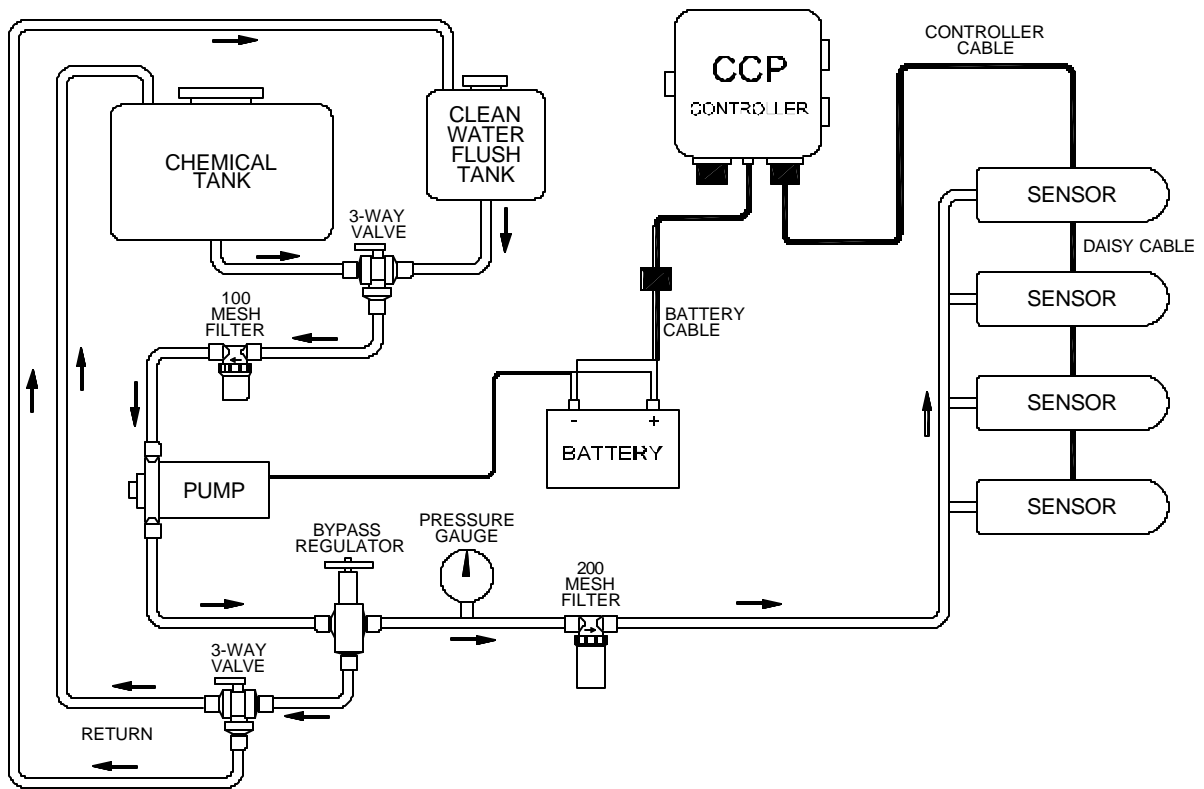

Figure 8: System Configuration

Plumbing Hookup

Figure 8 shows the necessary plumbing for a *WeedSeeker*[®] System.

In addition to the chemical tank, a flush tank is strongly recommended for a *WeedSeeker*[®] plumbing system. A three way Supply valve is used to route delivery of chemical or clear water to the Sensor's spray nozzles. When flushing the system, change positions on the "Return 3 Way Valve" to return fresh water back to the Clean Water Flush Tank and prevent dilution of Chemical in the tank.

A 100 mesh filter is recommended to protect the pump.

A 200 mesh filter must be installed between the regulator and the Sensors. Without this filter the cartridges will become clogged. In many cases the clogging will be severe enough that even back flushing will not unclog the valve cartridge.

The inlet line for each Sensor is 1/4 inch ID hose. The system connecting line should be 3/8 inch or 1/2 inch ID hose to ensure proper flow rates. To accommodate typical systems up to 12 spray units we include 20 feet of 3/8 inch ID hose for ease of installation.

Operating Instructions

Open the CCP Controller Box and familiarize the operator with the control panel. Refer to the Controller section of this manual if necessary for function descriptions.

Start up

Ensure the **FLUSH switch** is set in the **<OFF>** position. With the pump turned on (spray pressure of about 40 psi), turn the **POWER switch <ON>**. The **WARM UP light** will come on for approximately 20-30 seconds while the electronics get to the proper operating temperature.

While the warm up is occurring, the operator can make initial adjustments to the system such as the **SENSITIVITY** and **VEHICLE SPEED**.

Use 2.5 to 3 as a good starting point for **Sensitivity**. Then in the field adjust the sensitivity as necessary.

At too high of a setting you will lose sensitivity or the ability to see small weeds.
At too low of a setting you will be too sensitive and will tend to get "phantom" spraying.

If the vehicle speed is unknown, set the **SPEED switch** to **medium** and adjust as necessary once you start spraying.

If the spray pattern falls before the weed, reduce the **SPEED** setting.
If the spray pattern falls after of the weed, increase the **SPEED** setting.

When the **WARM UP light** goes off, the **SOIL BASE** switch is used to calibrate the Sensors' field of view. To do this, drive the sprayer over a bare (weed free) patch of ground and press the **SOIL BASE switch** momentarily. For best results, set the soil base in the field and not on the road at the end of the rows.

Press the **STANDBY switch** to turn the **STANDBY light <OFF>**. The **SOUND switch** should be set as desired.

As a final test, wave a weed (leaf) under each Sensor to confirm that each unit sprays. If there is a problem of recognizing the weed, check the sensitivity setting. If the problem persists, refer to the *WeedSeeker*[®] Troubleshooting Manual.

You are now ready to begin spraying.

Operation

Press the **SOIL BASE switch** to calibrate whenever soil conditions change. Do this step over a bare (weed free) patch of ground. For best results, set the soil base in the field and not on the road at the end of the rows.

Check periodically (i.e., hourly, or twice a day) that all *WeedSeeker*[®] Sensors are working properly. Turn the **FLUSH** switch to **ON**: check that all valve cartridge LED (red) lights are on and each nozzle is spraying. Stop the vehicle if necessary for this step.

At the same time check the Detector and Light Source Windows. If they are dusty or dirty use a soft rag to wipe them clean.

If you are going to drive for a distance (i.e., between spray areas), press the **STANDBY** switch to pause operation.

The **Lift Switch** light comes on when the Lift Switch attached to a Tool Bar on a Hooded Row Crop Sprayer is activated.

Care and Maintenance

Proper care and maintenance of your *WeedSeeker*[®] Selective Spray System are very important to ensure the highest level of performance your *WeedSeeker*[®] System is capable of delivering. At the end of each day of spraying, the following steps should be taken:

- Flush the entire system with clean water. To do this, switch to your clean water flush tank and turn **<On >** the **FLUSH switch**. This will clean all delivery systems of chemical residue.
- With the **FLUSH switch <On>** check each valve nozzle. If a Sensor ceases to spray, but the valve LED lights are still operating, the valve is clogged. To back flush a valve cartridge, see the Back Flush Procedure in the Troubleshooting Manual. **Caution: Removing the inlet hose while there is pressure and chemical in the line is a potential safety hazard. Turn the pump off and relieve the pressure in the line before removing the inlet hose.**
- Check the Detector and Light Source Windows for dust and dirt and wipe clean with a soft rag.

The *WeedSeeker*[®] System should not be left outdoors when exposed to extreme conditions. Temperature and moisture extremes could cause malfunctions in the system. Storage in freezing weather could split the Valve Cartridge if not first blown free of water.

If you experience operating problems, refer to the Troubleshooting Manual. Limit any fixes or repairs to those covered in the Troubleshooting Manual. Due to the complexity of these systems, do not attempt any field repair of a malfunctioning Controller or Sensors. Contact your local Dealer Representative or Patchen for assistance. Depending on the problem, your machine will be repaired by a qualified service technician or replaced by a unit from the factory.

WARRANTY STATEMENT

1. PATCHEN, INC. (PATCHEN) warrants each new product to be free from defects in material and workmanship for a period of **one (1) year from date of retail sale** established by the use of PATCHEN's Warranty Registration form. The obligations of PATCHEN under this warranty are limited to the repair or replacement, at PATCHEN's option, of defective parts of the product, which shall within one year from date of retail sale, be returned to PATCHEN, Ukiah, California, transportation charges prepaid. PATCHEN reserves the right to determine whether or not a defect exists for which it is responsible under this warranty.
2. This warranty is void if the product has not been installed or maintained in accordance with PATCHEN's instructions, been subjected to damage in an accident, abused or neglected during operation, repaired, altered or modified by persons other than PATCHEN's assigned service personnel, or failed to have normal maintenance as recommended in our Operator's Manual.
3. This warranty is exclusively limited to repair or replacement at PATCHEN's option, of product found to be defective. Labor charges, transportation charges, and consequential damages are not covered by this warranty. Further, PATCHEN disclaims any liability for any incidental damages, including lost or duplicated time or expense, accruing for any reason to the owner or user of any products sold by PATCHEN.
4. Because of our continuing policy of product improvement, PATCHEN reserves the right to make changes in its products without incurring any obligation to incorporate such improvements in any products previously sold or in service.
5. The foregoing warranty is exclusive and in lieu of all other express, statutory, and implied warranties including those of merchantability and fitness for any particular purpose or use.

APPLICATION OF WARRANTY

To make a claim under warranty, the customer must contact PATCHEN giving a description of the product and request instructions. **MERCHANDISE MUST NOT BE RETURNED TO PATCHEN UNTIL A RETURNED MATERIAL AUTHORIZATION (RMA) NUMBER IS ISSUED. EVIDENCE OF ORIGINAL PURCHASE MUST ACCOMPANY RETURN.**

Rev. 05/04/99